

ICOM

INSTRUCTION MANUAL



UHF TRUNKED RADIO

IC-F610
IC-F620



Icom Inc.

SAFETY TRAINING INFORMATION



WARNING

Your Icom radio generates RF electromagnetic energy during transmit mode. This radio is designed for and classified as “Occupational Use Only”, meaning it must be used only during the course of employment by individuals aware of the hazards,

and the ways to minimize such hazards. This radio is **NOT** intended for use by the “General Population” in an uncontrolled environment.

- For compliance with FCC and Industry Canada RF Exposure Requirements, the transmitter antenna installation shall comply with the following two conditions:
- The transmitter antenna gain shall not exceed 0 dBi.
- IC-F620:

The transmitter antenna is required to be located outside of a vehicle and kept at a separation distance of 37 centimeters or more between the transmitter antenna of this device and persons during operation.



CAUTION

To ensure that your exposure to RF electromagnetic energy is within the FCC allowable limits for occupational use, always adhere to the following guidelines:

- **DO NOT** operate the radio without a proper antenna attached, as this may damage the radio and may also cause you to exceed FCC RF exposure limits. A proper antenna is the antenna supplied with this radio by the manufacturer or an antenna specifically authorized by the manufacturer for use with this radio.
- **DO NOT** transmit for more than 50% of total radio use time (“50% duty cycle”). Transmitting more than 50% of the time can cause FCC RF exposure compliance requirements to be exceeded. The radio is transmitting when the “TX indicator” lights red. You can cause the radio to transmit by push the “PTT” switch.

Electromagnetic Interference/Compatibility

During transmissions, your Icom radio generates RF energy that can possibly cause interference with other devices or systems. To avoid such interference, turn off the radio in areas where signs are posted to do so. **DO NOT** operate the transmitter in areas that are sensitive to electromagnetic radiation such as hospitals, aircraft, and blasting sites.

FOREWORD

Thank you for purchasing this Icom product. The IC-F610/F620 UHF TRUNKED RADIOS are designed and built with Icom's superior technology and craftsmanship. With proper care, this product should provide you with years of trouble-free operation.

We want to take a couple of moments of your time to thank you for making your IC-F610/F620 your radio of choice, and hope you agree with Icom's philosophy of "technology first." Many hours of research and development went into the design of your IC-F610/F620.

◆ FEATURES



- **Compatible with MPT 1327/1343 Networks**
- **Short Data Message (SDM)**
- **32 Status Messages Capability**
- **MAP27 Data Communication Protocol, RS-232C PC Interface**
- **Optional Voice Scrambler Unit, UT-109/UT-110**
- **Flash ROM CPU, Firmware Upgrade Capability**
- **Keypad microphone (HM-152T) Available**

IMPORTANT

READ ALL INSTRUCTIONS carefully and completely before using the transceiver.

SAVE THIS INSTRUCTION MANUAL — This instruction manual contains important operating instructions for the **IC-F610/IC-F620 UHF TRUNKED RADIO**.

EXPLICIT DEFINITIONS

WORD	DEFINITION
 WARNING	Personal injury, fire hazard or electric shock may occur.
 CAUTION	Equipment damage may occur.
NOTE	If disregarded, inconvenience only. No risk of personal injury, fire or electric shock.

Icom, Icom Inc. and the  ICOM logo are registered trademarks of Icom Incorporated (Japan) in the United States, the United Kingdom, Germany, France, Spain, Russia and/or other countries.

PRECAUTION

⚠ WARNING! NEVER connect the transceiver to an AC outlet. This may pose a fire hazard or result in an electric shock.

⚠ NEVER connect the transceiver to a power source of more than 16 V DC such as a 24 V battery. This connection will ruin the transceiver.

⚠ NEVER cut the DC power cable between the DC plug and fuse holder. If an incorrect connection is made after cutting, the transceiver might be damaged.

⚠ NEVER place the transceiver where normal operation of the vehicle may be hindered or where it could cause bodily injury.

⚠ NEVER allow children to touch the transceiver.

⚠ NEVER expose the transceiver to rain, snow or any liquids.

USE supplied microphone only. Other microphones have different pin assignments and may damage the transceiver.

DO NOT use or place the transceiver in areas with temperatures below -22°F (-30°C) or above $+140^{\circ}\text{F}$ ($+60^{\circ}\text{C}$) or, in areas subject to direct sunlight, such as the dashboard.

AVOID operating the transceiver without running the vehicle's engine. The vehicle's battery will quickly run out if the transceiver is in transmission while the vehicle's engine OFF.

AVOID placing the transceiver in excessively dusty environments.

AVOID placing the transceiver against walls. This will obstruct heat dissipation.

AVOID the use of chemical agents such as benzine or alcohol when cleaning, as they damage the transceiver surfaces.

BE CAREFUL! The transceiver will become hot when operating continuously for long periods.

For U.S.A. only

CAUTION: Changes or modifications to this transceiver, not expressly approved by Icom Inc., could void your authority to operate this transceiver under FCC regulations.

TABLE OF CONTENTS

SAFETY TRAINING INFORMATION

FOREWORD	i
IMPORTANT	i
EXPLICIT DEFINITIONS	i
PRECAUTION	ii
TABLE OF CONTENTS	iii
1 PANEL DESCRIPTION	1-4
■ Front panel	1
■ Programmable key assignment	3
■ Function display	4
2 OPERATION	5-12
■ Turning power ON	5
■ General	5
◇ Opening text	5
■ Calling	6
◇ Making a call with a Memory Dial Number	6
◇ Making a call with a Memory Individual Code	7
◇ Calling the Despatcher	7
◇ Making a Status Call	8
◇ Sending a status message to the Despatcher	8
◇ Include Call	9
◇ PTT Quick Call function	9
■ Making a call via the keypad	9
◇ Individual Call	9
◇ Group Call	10
◇ Status Call	10
◇ Enhanced Group Call	10
◇ Priority Call	10
◇ Emergency Call	11
◇ System Wide Call	11
◇ PSTN Call	11
◇ PABX Call	11
◇ Divert Own Call	11
◇ Divert 3rd Party Call	11
◇ Cancellation of Divert	11

◇ SDM (Short Data Message) Call	12
◇ 5-Digit Routing code calling	12
◇ Cancellation of calling	12
◇ Cancellation of Input	12
■ Special calling via the keypad	12
◇ ReDial	12
◇ Short Dialling	12
3 RECEIVING	13-15
■ Receiving a call	13
◇ Reception of an Individual Call	13
◇ Reception of a Group Call	13
◇ Reception of a Status Call	14
◇ Reception of a SDM (Short Data Message) Call	14
■ Progress messages	15
4 OTHER FUNCTION	16-18
◇ Call Back function	16
◇ DTMF function	16
◇ Scrambler function	17
◇ Compander function	17
◇ Mic Hook OFF function	17
◇ Mic Hook ON function	17
◇ Horn Honk function	17
◇ Public Address function	17
◇ RX Speaker function	18
◇ Ignition SW function	18
◇ Auto Talk Around function	18
5 USER SETUP MENU	19
■ User Setup Menu	19
◇ Selectable items and setting value	19
6 MAP27	20
■ MAP27 serial interface	20

7 CONVENTIONAL MODE	21-22
■ Conventional mode operation	21
■ Programmable key assignment	21
8 CONNECTION AND MAINTENANCE ...	23-27
■ Rear panel and connection	23
■ Supplied Accessories	24
■ Mounting the transceiver	25
◇ Inverting the Front panel	25
◇ Mounting the transceiver	26
■ Optional UT-109/UT-110 installation	26
■ Optional OPC-617 installation	27
■ Antenna	27
■ Fuse replacement	27
■ Cleaning	27
9 CLONING	28
■ Cloning	28
10 OPTIONS	29

1

PANEL DESCRIPTION

■ Front panel

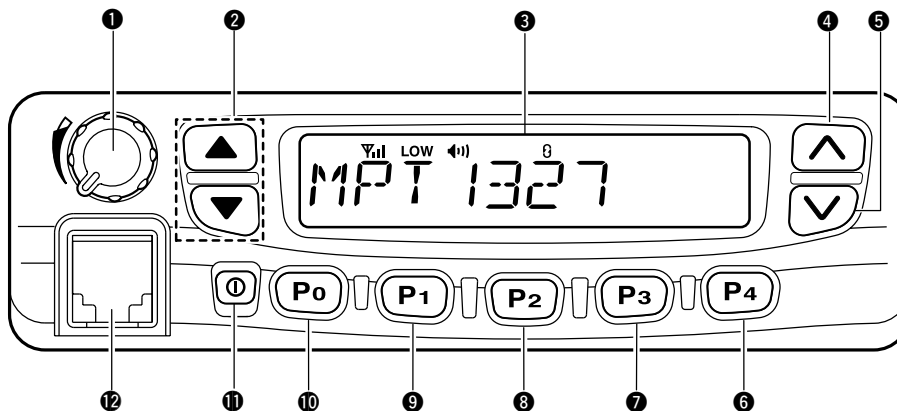

1 AF VOLUME CONTROL KNOB

Rotate the knob to adjust the audio output level.

- Minimum audio level is pre-programmed.

2 STATUS UP/DOWN (LEFT UP/DOWN) KEYS* [▲]/[▼]

Pushing these keys will scroll up/down the status memory.

3 FUNCTION DISPLAY

Displays a variety of information, such as dialling numbers, texts, status and message, etc.

4 MEMORY UP (RIGHT UP) KEY* [^]

- ➔ Pushing the key will scroll up to the next stored code.
- ➔ If the stored calls are displayed by pushing the Call Back key, this key scrolls up the screen.
- ➔ While entering the dial number via the optional microphone keypad, push the key to delete the last digit as a back-space key.

5 MEMORY DOWN (RIGHT DOWN) KEY* [✓]

- If the stored calls are displayed by pushing the Call Back key, this key scrolls down the screen.
- While entering the dial number via the optional microphone keypad, push the key to delete the last digit as a backspace key.

6 CLEAR KEY* [Clear/P4]

- If this key is pushed during a call, the call is finished.
- If the key is push and held down for 2.5 sec., the User Setup Menu appears (or the user setup menu is cancelled).
- Pushing the key to cancel any keypad operation, and return to normal mode.

7 CALL BACK KEY* [Call Back/P3]

- Pushing this key will display the stored calls that you have not answered yet.
- Pushing the key again will return to the standby mode.
- Push and hold the key for 2.5 sec., the Call Back mode turns ON or OFF. While the Call Back mode is turned ON, received calls are stored in the LOG, then the Call Back message is automatically sent back to the called station.

8 MODE KEY* [Mode/P2]

Push to toggle the mode between MPT and convention.

9 EMERGENCY KEY* [Emergency/P1]

Push and hold for 2.5 sec. to initiate an Emergency Call(*9) to the pre-determined station or current station (Selectable Emergency Function; p. 11).

10 DESPATCHER KEY* [Despatcher/P0]

- Pushing the key will display the screen in the Despatcher mode.
- Pushing the key again will display a status code (if permitted by the settings).
- Pushing the key again will go to the standby mode.

11 POWER SWITCH [POWER]

Push to turn the power ON and OFF.

- The following functions are available at power ON as options:
 - Password prompt

12 MICROPHONE CONNECTOR

Connect the supplied microphone, or optional DTMF microphone for dialling operation via the keypad.

MICROPHONE

The supplied microphone has a PTT switch and a hanger hook.

- The following functions are available when the microphone is on or off hook:
 - hook off: Answer
 - hook on: Clear Down

*Programmable function keys and default key assignment.

■ Programmable key assignment

Dealer programmable keys [P₀], [P₁], [P₂], [P₃], left Up/Down [▲]/[▼] and right Up/Down [^]/[v] can be programmed for one of several functions by your Icom dealer.

In the following explanations, programmable function names are bracketed; the specific switch used to activate the function depends on programming.

Trunking mode only:

[Despatcher]([P₀])*

The exclusive key used to call the despatcher.

[Call1], [Call2]

The exclusive key used to call the pre-programmed station.

[Emergency]([P₁])*

The exclusive key used to call the pre-programmed Emergency station.

[Clear]([P₄])*

Push this key to clear down the communication.

Push and hold the key for 2.5 seconds when your transceiver is in the standby mode (not during communication, dialling or operation), the User Setup Menu (p. 19) appears.

[Call Back]

Push this key to turn the Call Back function ON or OFF.

Push the key will display the stored calls that you have not yet answered. **[Status Up] [Status Down]([▲]/[▼])***

This key is used to select the status memory.

[Memory Up] [Memory Down]([^]/[v])*

This key is used to select the Memory channel.

*Default key assignments.

Either Trunking or Conventional mode;

[Mode]

Push the key to toggles between Trunking mode and Conventional mode.

[Null]

No function is assigned.

[High/Low]

Pushing the key will toggle in the order of Low1 power, Low2 power, High power and Auto power.

[Public Address]

Use the transceiver as an audio amplifier.

[RX Speaker]

Output the receive audio to an out-of-vehicle speaker.

■ Function display

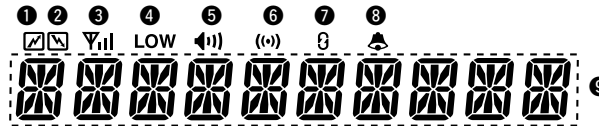

❶ TRANSMIT INDICATOR

Appears while transmitting.

❷ RECEIVE INDICATOR

Appears while receiving a message.

❸ SIGNAL STRENGTH METER

Indicates the received signal strength at 4 levels.

- If the connection with the communication network is not established, the whole icon turns OFF while ∇ il blinks.
- For a stable communication, at least the second highest level (with two bars appearing) is required.

❹ LOW POWER INDICATOR

Appears if the transmission output is set to a low power level (Low1 or Low2). Does not appear when High power is selected.

❺ SPEAKER INDICATOR

Appears when voice communication becomes possible.

❻ COMPANDER INDICATOR

Appears when the compander function that improves the communication quality, is activated.

❼ SCRAMBLER INDICATOR

Appears when the scrambler is activated.

❽ CALL BACK INDICATOR

Blinks if any call number to which you have not yet answered is stored.

❾ ALPHANUMERIC DISPLAY

Indicates personal ID, opening text, etc., according to operating condition.

■ Turning power ON

- ① Push **Ⓚ** to turn the power ON.
 - A power-up alert tone sounds for about 1 sec. and an opening message may appear.
- ② If the transceiver is programmed for a start up passcode, input the digit codes as directed by your dealer.
 - The keys in the table below can be used for password input.
 - The transceiver detects numbers in the same block as identical. Therefore “01234” and “56789” are the same.
- ③ When the “PASSWORD” indication does not clear after inputting digit codes, the input code number may be incorrect. Turn the power off and start over in this case.

KEY	[P ₀]	[P ₁]	[P ₂]	[P ₃]	[P ₄]
NUMBER	0	1	2	3	4
	5	6	7	8	9

■ General

Push **Ⓚ** to turn the power ON. A power-up alert tone will be heard. Push **Ⓚ** again to turn the power OFF. The following information will sequentially appear on the display.

◇ Opening text

The pre-programmed opening text and individual ID will appear.

The individual ID consisting of a prefix code (3 digits) + a fleet code (2 digits)+ an individual code (2 or 3 digits) will appear. (e.g.) If the prefix code is 200, the fleet code 2001, and the individual code 300, the individual ID will be ‘2002001300’.

(OPENING TEXT)

201 2001 300

- If you are within the trunking service area, the code (selected by [**^**]/[**∇**]) and the received signal strength, are displayed to indicate that communication is possible.

-TEXT-

*In the “-TEXT-” part, the characters pre-programmed by cloning software will be displayed.

- If you are outside of the trunking service area, or if the system is down, **YIL** will blink.

At this time, the transceiver is searching for any available system-controlled channel.

■ Calling

◇ Making a call with a Memory Dial Number

Using [**^**]/[**v**], select one of the group codes that is stored in the memory.

[**^**]/[**v**] allows you to select any group code from the 40 dial numbers.

- ① Select the desired dial number by pushing [**^**] or [**v**].
- ② Push [PTT] to make a call with the selected dial number.
- ③ With 'Calling' displayed, the intermittent beep sound for calling will be heard.

CALLING

- ④ With 'Connected' displayed, the speaker icon will appear allowing you to start the communication. At the same time, the count-down timer will appear to limit the communication time.

CONNECTED

- ⑤ A warning beep will be emitted 10 seconds before the communication timer reaches the limit. When the limit has been reached, the communication will be disconnected automatically.

TIME 1 59

- ⑥ To manually end the communication, push [Clear]. (or push [*****], then push [**#**]).

CLEAR DOWN

2 OPERATION

◆ Making a call with a Memory Individual Code

Push [^]/[v] to select a memory individual code to make the call.

- ① Display an individual code by push [^]/[v].
- ② Select the desired individual code using [^]/[v].

PERSONAL 1

- ③ Push [PTT] to start calling with the selected individual code.
- ④ While 'Calling' is displayed, the intermittent beep sound for calling will be heard.
- ⑤ With 'Connected' displayed,  will appear allowing you to start the communication. At the same time, the count-down timer will appear to limit the communication time.
- ⑥ A warning sound will be emitted 10 seconds before the communication timer reaches the limit. When the limit has been reached, the communication will be disconnected automatically.
- ⑦ To manually end the communication, push the [Clear] key. (or push [*], then push [#]).

◆ Calling the Dispatcher

The dispatcher may be called directly.

- ① Push the [Dispatcher] key.

DISPATCHER

- ② Push the [PTT] key. The call to the dispatcher will be started.
NOTE: If calling direct to the Dispatcher is prohibited, the status message 00 (or 0) (Call Back Request) is transmitted and then the transceiver will return to the waiting mode.
- ③ While 'Calling' is displayed, the intermittent beep sound will be heard.
- ④ With 'Connected' is displayed,  will appear allowing you to start the communication. At the same time, the count-down timer will appear to limit the communication time.
- ⑤ A warning sound will be emitted 10 seconds before the communication timer reaches the limit. When the limit has been reached, the communication will be disconnected automatically.
- ⑥ Push [Clear] to manually end the communication.

◇ Making a Status Call

A status message may be sent to the despatcher or a remote station having an individual code. (No status message can be sent to any station using a group code.)

• Sending a status message to a station having an individual code.

- ① Display an individual code by pushing [▲]/[▼].

PERSONAL 1

- ② Push the Status Up [▲]/Down [▼] to enter the status code select mode.

STATUS 01

- Select the desired message from a total of 32 different status messages having code No. 0 through 31.
 - Status code 0 means “Call Back Request” -- Please call back, and status code 31 “Previous Request Cancel” -- Cancels the call. These status codes are commonly used by all systems.
- ③ Push [PTT], the status message will be sent to the station having the selected individual code.
- ④ When the status message has been successfully sent out, ‘OK’ appears on the display.

◇ Sending a status message to the Despatcher

- ① Enter the Despatcher mode by pushing the [Despatcher].

DESPATCHER

- ② Push [Despatcher] again. Now you are ready to select a status code.

STATUS 01

- If the direct call to the despatcher is selected, you cannot use status code select condition.
- ③ Push [▲]/[▼] to select the desired status message.
- Select the desired message from a total of 32 different status messages having code No. 0 through 31.
 - Status code 0 means “Call Back Request” -- Please call back, and status code 31 “Previous Request Cancel” -- Cancels the call. These status codes are commonly used by all systems.
- ④ Push [PTT] to send the status message to the despatcher.
- ⑤ When the status message has been successfully sent out, ‘OK’ appears on the display.

2 OPERATION

◇ Include Call

- After moving to the communication channel, you can make an additional call to the other station for them join in to the communication with you.
 - ➔ Make a call with a memory individual/group call or make a call via the keypad on the communication channel to start the Include call.

◇ PTT Quick Call function

The Despatcher, Status message, Call Back memory selected by function key or the currently selected memory group (current group) can be called only by push [PTT].

■ Making a call via the keypad

Various calls can be made by the following keying sequences via the keypad*.

*HM-152T optional DTMF microphone is required.

**Turn the 'DTMF Mic' function in the 'Common-Common' menu of the cloning software to 'Enable' when using this function. Please consult your dealer.

◇ Individual Call

- **Individual call to a station having the same prefix and fleet codes.**

Enter an individual code via the keypad and then push [#]. The individual call will be started.

(e.g.) To call 200 2001 300 from 200 2001 200, enter '300#'.

- **Individual Call to a station having the same prefix code and a different fleet code.**

Enter the fleet code plus the individual code via the keypad and then push [#]. The individual call will be started.

(e.g.) To call 200 2006 300 from 200 2001 200, enter 2006300#.

- **Individual Call to a station having a different prefix code.**

Enter the prefix code plus the fleet code plus the individual code via the keypad and then push [#]. The individual call will be started.

(e.g.) To call 211 2006 300 from 200 2001 200, enter 2112006300#.

NOTE: Instead of pushing [#], push [PTT] can be also make the call.

◇ Group Call

- **Group Call to the stations having the same prefix and fleet codes.**

Enter the group code via the keypad and then push [#]. The group call will be started.

(e.g.) To call 200 5001 91 from 200 2001 200, enter 91#.

- **Group Call to the stations having the same prefix code and a different fleet code.**

Enter the fleet code plus the group code via the keypad and then push [#]. The group call will be started.

(e.g.) To call 200 6002 90 from 200 2001 200, enter 600290#.

- **Group Call to the stations having a different prefix code.**

Enter the prefix code plus the fleet code plus the group code via the keypad and then push [#]. The group call will be started.

(e.g.) To call 211 6002 90 from 200 2001 200, enter 211600290#.

◇ Status Call

- Enter *0xx (xx: a status code in the range between 00 and 31) and then push [#]. The status call to the despatcher will be started.

(e.g.) To send status code 02 to 200 2001 300 from 200 2001 200, enter *002*300#. You can omit the first "0" between status 00 and 09, for example as *02*300#.

- To make the Call Back request of the status call to the despatcher, enter *0#.

- To make the cancellation of the above request to the despatcher, enter #0#.

- To make the Call Back request of the status call to the individual code station, enter *0* plus an individual code plus [#].

- To make the cancellation of the above request to the individual code station, enter #0* plus an individual code plus [#].

◇ Enhanced Group Call

- **To make a Conference Call;**

Enter *1* plus a group code and then push [#]. The conference call will be started allowing the called stations to have communication.

- **To make a Broadcast Call;**

Enter *11* plus a group code and then push [#]. The broadcast call will be started allowing the called stations only to listen to the call.

◇ Priority Call

- Enter *8* plus an individual call/a Group call and so on, then push [#]. The priority call will be started.

➡ If the system is busy (no channel is available), the priority is given on a first-come-first-served basis.

2 OPERATION

◇ Emergency Call

- Enter ***9*** plus an individual code or a group code and then push [#]. The emergency call will be started.

'Selectable Emergency Function; Disable*'

- ➔ Enter ***9**, then push [#]. The pre-programmed 'Emergency Number' used for the emergency call.

'Selectable Emergency Function; Enable*'

- ➔ Enter ***9**, then push [#]. The current 'Dial Number' selected via [^]/[v] used for the emergency call.
 - If the system is busy (no channel is available), a channel is forcibly made available allowing you to establish the communication.

'Selectable Emergency Function' can be set with the cloning software (p. 28).

◇ System Wide Call

- Entering ***1981#** will allow you to make a priority voice call.
- Entering ***1982#** will allow you to make a voice call.
- Entering ***1987#** will allow you to make a standard voice call.
 - ➔ Each of the above calls is used to call all the mobile stations that are waiting on the system.

◇ PSTN Call

Enter 0 plus a telephone number (8 digits or more) and then push [#]. The PSTN call will be started.

◇ PABX Call

Enter 0 plus a telephone number (5 to 7 digits) and then push [#]. The PABX call will be started.

◇ Divert Own Call

- Enter ***41n*** plus the individual code of the station you want to divert your own call to, and then push [#].
 - This will allow you to divert your own call to the specified station.
 - ➔ In the place of 'n', enter 1 for voice, 0 for data, or nothing for both voice and data.
- Enter **#41n***, then push [#] to cancel the diversion. Or enter **#45n#** to cancel the above diversion on the station you want to divert your own call to.

◇ Divert 3rd Party Call

- Enter ***44n*** plus Station B's individual code plus ***** plus Station A's individual code (destination), and then push [#]. Station B's call will be diverted to Station A.
 - ➔ In the place of 'n', enter 1 for voice, 0 for data, or nothing for both voice and data.
- Enter **#44n*** plus station B's individual code, and then push [#] to cancel this diverting.

◇ Cancellation of Divert

- Enter **#41n** and then push [#]. This will allow you to cancel the Divert Own call.

- Enter #44n* plus station B's individual code and then push [#]. This will allow you to cancel the Divert 3rd Party call.
- Enter #45n and then push [#]. This will allow you to cancel the call that diverted to you.
 - In the place of 'n', enter 1 for voice, 0 for data, or nothing for both voice and data.

◇ SDM (Short Data Message) Call

- Enter *2* plus data (up to 24 digits in total) via the keypad and then push [#]. This will allow you to make a data call to a predetermined station.
- Enter *2* plus data via the keypad plus individual code (up to 24 digits in total) and then push [#]. This will allow you to make a data call to an individual code station.

◇ 5-Digit Routing code calling

Converting a prefix code (3 digits) plus a fleet code (4 digits) to 3 digits allows you to dial a different prefix code and fleet code by 5 digit dialling.

- Convertible numbers; 200 to 299, 900 to 999, 20 to 29, 90 to 99.
 - *Pre-program the prefix and fleet numbers before converting.

• Individual calling with different prefix code.

To call 211 2006 300 from 200 2001 200;

- Pre-program 22 to prefix code 211 and fleet code 2006 as 5-Digit Routing code. Enter 22300# to start the call.

◇ Cancellation of calling

Enter * and then push [#]. This will allow you to cancel the current call.

- This will allow you to end the communication or cancel the current call.

◇ Cancellation of Input

When you are entering data via the keypad, push [^]/[v]. This will delete the data starting with the last character/digit entered, allowing you to restart entering the data again. Push [Clear] to cancel the inputting and return to the waiting mode.

■ Special calling via the keypad

◇ ReDial

Enter ## via the keypad. This will allow you to redial the last number called.

◇ Short Dialling

Enter # followed by the memory location (1 to 9). This allows you to automatically dial a commonly used number from memory 1 to 9 by pushing [^]/[v].

■ Receiving a call

◇ Reception of an Individual Call

When an individual call is received, the telephone beep sounds telling you that a call has been received. Immediately after this, you can talk with the caller.

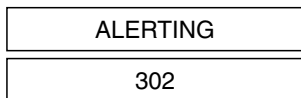

*Message and individual code displayed alternately.

- ① The caller's individual code and count-down timer will appear on the LCD screen.

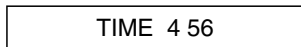



➡ If the call is from a telephone (PSTN call) or PABX (PABX call) will be displayed.



- ② Pushing [PTT] will allow you to talk with the caller. The transmission indicator  will appear on the LCD.
- ③ During the communication, the timer will count the communication time. When the limit has been reached, the communication will be automatically shut down (clear down).

- ④ To end the communication manually, push [Clear] or push [*] then [#].
- ⑤ The transceiver will return to the waiting mode.

• If you do not answer the call;

- ⑥ If you did not answer the call by not push [PTT], the caller's number is stored in the Call Back memory. Up to 15 non-answered calls are stored. If there is any non-answered call remaining in the memory, the Call Back icon  blinks.
- ⑦ Select the Call Back memory by pushing [Call Back] and []/[], then push [PTT]. This will allow you to call the stored unanswered call.



◇ Reception of a Group Call

You can receive a group call with a pre-programmed group code number or the group code that has been selected via [^]/[v].

When a group call is received, the beep sound is emitted and you immediately are able to communicate.

- ① The LCD screen displays the caller's individual code.

GRP 200

- In the case of a call received from the Inter-Prefix, 'INTER-PFIX' is displayed on the LCD screen.
- The communication time timer will appear on the display.

TIME 00 56

- ② The individual ID will appear if 'Display Pressel' function is enabled, and remain displayed during the current communication.
- ③ Pushing [PTT] will allow you to talk with the caller.
 - In the case of a group call, the communication only can be cleared down from the caller's side. The called station cannot clear down the communication.

◇ Reception of a Status Call

When a status call is received, a beep sound is heard.

- ① The LCD screen displays the text corresponding to the status number and the caller's individual code.

STATUS 01

302

- ② These text and the individual numbers remain until [Clear] is pushed.
- ③ If you push [Clear] to cancel the displayed status call, the transceiver returns to the waiting mode.

◇ Reception of a SDM (Short Data Message) Call

When the Short Data Message is received, a beep sound is heard.

- ① The LCD screen displays the received data and the caller's individual code, and then the display blinks.

(DATA)

302

- ② Push [^]/[v] to display the following data when over 10 digits of data has been received.
- ③ No transmission can be made until the displayed data message is cancelled by pushing [Clear].
- ④ If you push [Clear] to cancel the displayed short data message, the transceiver returns to the waiting mode.



■ Progress messages

The following messages appear corresponding to the progress of the processing of a call.



MESSAGE	DESCRIPTION
ABORTED	Your call has been aborted (Wait for a while and then make the call again).
CALLING	Your call is now being processed.
CALL BACK	Your call has been recorded at the called station (Wait for a reply).
DIVERTED	Your call has been diverted to another station.
ENGAGED	The called station has not received your call since the line is busy (Wait for a while and then make the call again).
INVALID	You have entered an invalid number.
NO REPLY	Your call has not been answered.
QUEUED	Your call has been put in the waiting list (Wait for a while until your call is connected).
RINGING	The called station is now ringing.
SYS BUSY	The system is so busy that no call is accepted now (Wait for a while and then make the call again).

MESSAGE	DESCRIPTION
TIMEOUT	The communication time limit has been exceeded (The communication has already been ended).
FAILED	Your call has failed or your called number is not supported by the system.
CANCELLED	Your call has been cancelled.
CONNECTED	Your call has been connected successfully.
SYS WIDE	System Wide calls are accepted now.
TELEPHONE	PSTN calls are accepted now.
PABX	PABX calls are accepted now.
INTER-PFIX	Calls from stations having different prefix codes are accepted now.
CLEAR DOWN ...	End the communication.

◇ Call Back function

- If you do not want to answer the call immediately, use this function.
 - ↳ Pushing [Call Back] will allow you to enable or disable the function.
- When this function is enabled, the transceiver sends the Call Back to the called station. "CALL BACK" will be displayed on the called station's display, or, when you did not answer the call or the called station has cleared down before you answered the call while this function is disabled, the caller's number is automatically retained in the memory.
- Up to 15 non-answered calls will be stored.
- When a call is received, the caller's number is automatically retained in the memory.
- At the same time,  starts blinking to tell the user that there is the non-answered call stored in the memory.
-  will continue to blink until you have answered all the non-answered calls, or until you have cleared the memory.
- When you push [Call Back] to confirm the memorized contents,  stops blinking.
- All the retained non-answered calls are cleared when the power is turned OFF.
Even if the Call Back function is enabled, calls can be made normally.

• Call Back

- ① If you push [Call Back] when the  is blinking or lights, the memory numbers are displayed.
- ② A memory number can be selected using []/[].
- ③ Select a number and then push [PTT]. The selected number will be dialled to call back.
- ④ The number called back will be deleted from the memory.
- ⑤ You cannot call back to any PSTN or PABX call. The calls are recorded only.
- ⑥ To delete a memory number without calling back to that number, push [Call Back] and display the number using the Up and Down keys.
- ⑦ Push the [Call Back] key for 2.5 seconds. The number will be deleted from the memory.

◇ DTMF function

This function allows you to send a DTMF code via the HM-152T (optional DTMF microphone) while still being able to communicate with the [PTT] switch on the traffic channel.

NOTE: Key pads of HM-152T functions during standby mode as follows;

- 0 to 9, * and # for dialling.
- A: [P₀], B: [P₁], C: [P₂] and D: [P₃] of front panel.

4 OTHER FUNCTION

◇ Scrambler function

The transceiver is compatible with the optional UT-109 (#02) scrambler unit.

➡ Pre-programmed 5 scrambler code can be selected in the User Setup Menu. (p. 19)

NOTE: UT-109 is recommended for trunking operation. Both UT-110 and UT-109 are recommended for conventional operation.

◇ Compander function

The compander function provides clear audio quality in noisy environments. (p. 19)

◇ Mic Hook OFF function

This function allows you to answer back when receiving the individual call.

➡ Select 'Answer (ANS)' in 'Hook' in the User Setup menu. (p. 19)

◇ Mic Hook ON function

This function activates to clear down at the end of the conversation. (p. 19)

➡ Select 'Clear (CLR)' in 'Hook' in the User Setup menu.

NOTE: Select 'ON' on the 'Hook' in the User Setup menu when you use both 'ANS' and 'CLR'.

◇ Horn Honk function

(optional OPC-617 is required)

The Horn Honk function enables you to turn Horn Honk ON for a fixed period when receiving a status call or 'ALERTING' is displayed during an individual call.

➡ Select 'ON' in 'Horn' in the User Setup menu. (p. 19)

◇ Public Address function

(optional OPC-617 is required)

While pushing and holding [PTT] on the microphone, you can use the transceiver as an audio amplifier. External audio amplifier and speaker are required.

◆ RX Speaker function

(optional OPC-617 is required)

Output the receive audio to an out-of-vehicle speaker. External audio amplifier and speaker are required.

◆ Ignition SW function

The transceiver's power turns ON/OFF automatically depending on the ignition switch position. This function requires additional optional wiring cables. Please consult your dealer.

◆ Auto Talk Around function

If the transceiver loses the TSC (Trunking System controller) signal, the transceiver turns to conventional mode, and then the conventional channel is automatically selected. The transceiver will periodically scan the trunking channel, and automatically return to the trunking mode when any valid control channel is available.

■ User Setup Menu

By pushing and holding down the [Clear/P4] key for 2.5 seconds when your transceiver is in the standby mode (not during communication, dialling, or operation), the User Setup menu appears.

The User Setup menu allows you to use the settings for the backlight, Ringer level, beep level, compander ON/OFF, microphone gain, squelch level, AF minimum level, Scrambler, Hook and Horn settings.

- ① Push and hold the [Clear/P4] key for 2.5 seconds to display the User's Setup menu.
- ② Push and hold the [Clear/P4] key for another 2.5 seconds will return to the waiting mode.
- ③ Select the desired item by pushing [Clear/P4].
- ④ An option within the item can be selected using [^]/[v].

*Pushing [Clear/P4] will return to the setting for 'Back Light.'

◆ Selectable items and setting value

SELECTABLE ITEM	[v] ↔ [^]
• Back Light	OFF, DIM, Auto and ON
• Ringer Level	OFF, 1 to 5
• Beep Level	OFF, 1 to 5
• Compander	ON or OFF
• MIC Gain	1 to 5

*Following menu may not available as default settings. Please consult your dealer for details.

• SQL Level	0 to 255**
• AF Min Level	0 to 255
• Scrambler	OFF, 1 to 5
• Hook	OFF, Clear, Answer or ON
• Horn	OFF or ON

**Do not decrease lower than the default levels, otherwise communication interruption may occur during the trunking operation.

MAP27 serial interface

MAP27 is a Mobile Access Protocol for MPT1327/1343 communication equipment. It permits data exchange between MPT radio equipment and external equipment such as a data terminal which may be a laptop computer.

By connecting the OPC-822 OPTIONAL INTERFACE CABLE to the external connector of the transceiver (J9), you can use the serial interface*. (See right.)

*Available baud rate: 1200/2400/4800/9600

Using the appropriate PC software, you can control dialling, hook off (answer), hook on (clear down), status and short data from the computer.

The interface supports the following functions.

- Independent Call, Group Call
- Emergency Call (call with “*9”)
- Clear down
- Send/receive status messages
- Send/receive SDM (Short Data Message): up to 100 ASCII characters

NOTE: Follow the instruction manuals of MAP27 equipment for operation.

•OPC-822 (OPTION) installation

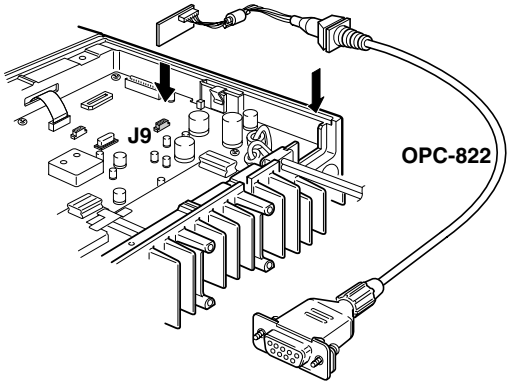

■ Conventional Mode operation

This transceiver has conventional mode capability. You can use up to 32 pre-programmed conventional channels. These channels can be selected with the [**▲**] or [**▼**].

➔ Push the [Mode] key assigned as the dealer programmable key to toggle between Trunking mode and Conventional mode. The transceiver memorizes the operating mode until Mode key is pushed, even if the power is turned OFF.

NOTE: You must assign the [Mode] function to a dealer programmable key, both for the Trunking mode and the Conventional mode in the key Assign screen of the cloning software.

- CTCSS tone squelch function is available in the Conventional mode. You can select the desired operating channel and make a communication with [PTT].
- While the Conventional mode is selected, the [Clear/P4] key functions as [Monitor]. (Default setting.)
 - ➔ Pushing this key allows you to open the transceiver's squelch manually to check whether a channel is busy or not.

■ Programmable key assignment

Dealer programmable keys [**P0**], [**P1**], [**P2**], [**P3**], [**P4**], [**OP F0**], [**OP F1**], [**OP F2**], [**▲**], [**▼**], [**▲**] and [**▼**] can be programmed for one of several functions by your Icom dealer. In the following explanations, programmable function names are bracketed; the specific switch used to activate the function depends on programming.

Conventional mode only;

[Monitor]

The monitor function allows you to open the transceiver's squelch manually to check whether a channel is busy or not.

[CH Up]/[CH Down]

Push to select the operating channel.

[Simplex]

The Simplex function changes duplex channels to simplex channels.

Simplex allows you to contact other portable transceivers directly.

Either Trunking or Conventional mode;**[Mode]**

Push this key to toggle between Trunking mode and Conventional mode.

[Null]

No function is assigned.

[High/Low]

Pushing this key will toggle in the order of Low1 power, Low2 power, High power and Auto power.

[Public Address]

Use the transceiver as an amplifier.

[RX Speaker]

Output the receive audio to an out of vehicle speaker.

8

CONNECTION AND MAINTENANCE

■ Rear panel and connection

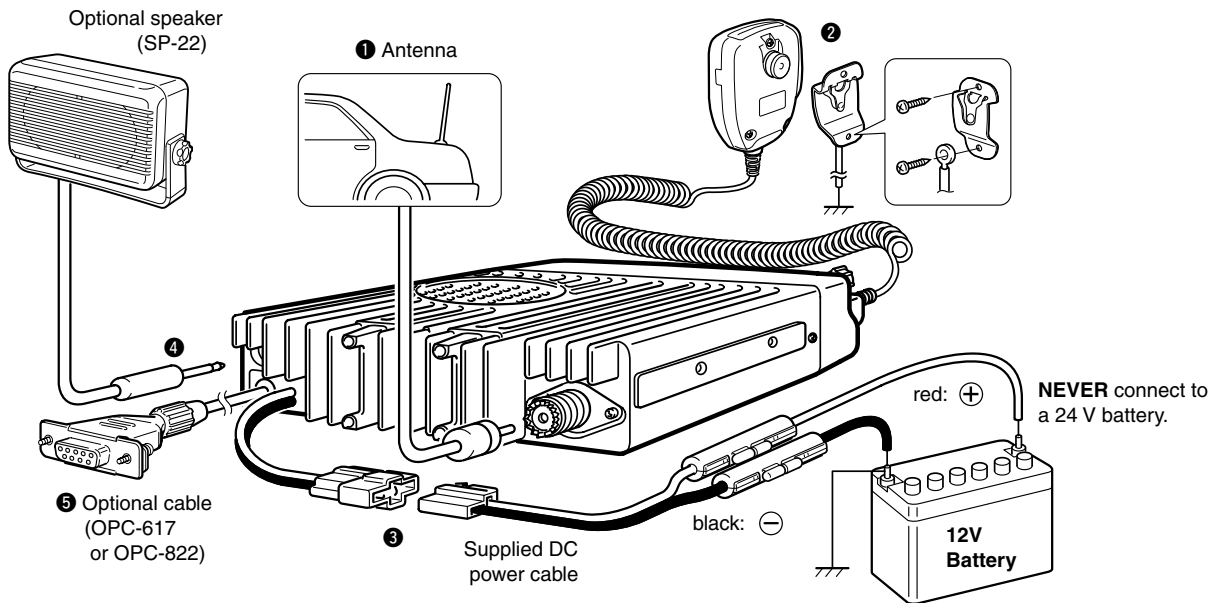

Note: Use the terminals for the cable connections.

The diagram shows two methods for connecting cable terminals:

- Crimp:** A crimping tool is used to attach a terminal to a wire.
- Solder:** Solder is used to attach a terminal to a wire.

1 ANTENNA CONNECTOR

Connects to an antenna. Ask your Dealer about antenna selection and placement.

2 MICROPHONE HANGER

Connect the supplied microphone hanger to the vehicle's ground for microphone on/off hook functions.

3 DC POWER RECEPTACLE

Connects to a **12 V DC** battery. Pay attention to polarities. **NEVER** connect to a **24 V** battery. This could damage the transceiver.

4 EXTERNAL SPEAKER JACK

Connect a 4–8 Ω external speaker, if desired.

5 OPTIONAL CABLE (OPC-617 or OPC-822)

Connect an external horn drive unit, LCD backlight control, etc.

Supplied Accessories

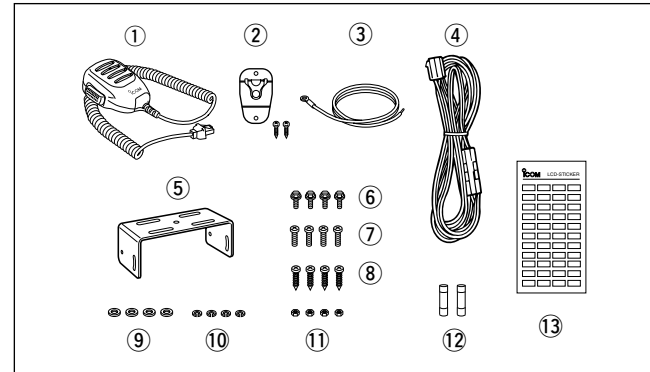

① Microphone	1	⑨ Flat washers	4
② Microphone hanger and screw set	1 set	⑩ Spring washers	4
③ Microphone hanger cable .	1	⑪ Nuts	4
④ DC power cable (OPC-345)	1	⑫ Fuses (15 A)	2
⑤ Mounting bracket	1	⑬ Function name stickers* (1705 LCD SEAL(E))	1
⑥ Bracket bolts	4		
⑦ Mounting screws (M5×12) .	4		
⑧ Self-tapping screws (M5×20)	4		

***Function name stickers**

There are no names on the programmable function keys since the needed functions can be assigned to these keys. Attach the supplied function name stickers above the appropriate keys.

■ Mounting the transceiver

The front panel can be inverted for correct viewing while leaving the built-in speaker facing away from the mounting surface.

◇ Inverting the Front panel

- ① Unscrew the 2-side screws.
- ② Detach the Front panel forward from the transceiver.
- ③ Bend the flat cable between Front panel and main unit as shown in the following diagram.
- ④ Invert the transceiver 180 degrees clockwise as below.
- ⑤ Re-attach the Front panel to the transceiver.
- ⑥ Tighten the 2 screws.

CAUTION:

NEVER rotate the transceiver more than 180 degrees.
DO NOT bend the flat cable too hard. Damage may occur.

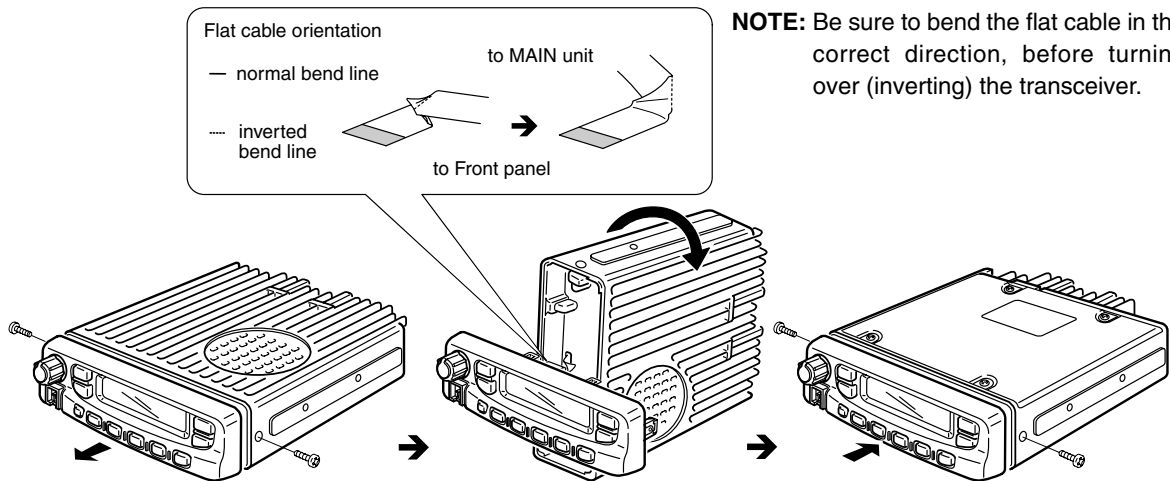

◇ Mounting the transceiver

The universal mounting bracket supplied with your transceiver allows overhead mounting.

- Mount the transceiver securely with the 4 supplied screws to a thick surface which can support more than 1.5 kg.

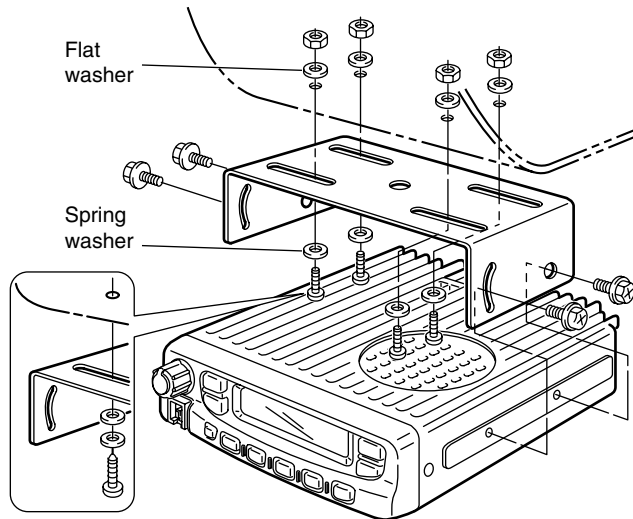

When using self-tapping screws

■ Optional UT-109 /UT-110 installation

- ① Turn power OFF, then disconnect the DC power cable.
- ② Unscrew the 4 screws, then remove the bottom cover.
- ③ Cut the print pattern on the PCB at the TX mic circuit (A) and RX AF circuit (B) as shown in the following figure.
- ④ Install the scrambler unit as shown in the following left.
- ⑤ Return the bottom cover and screws to the original position.

• Install the unit

• Cut the print pattern

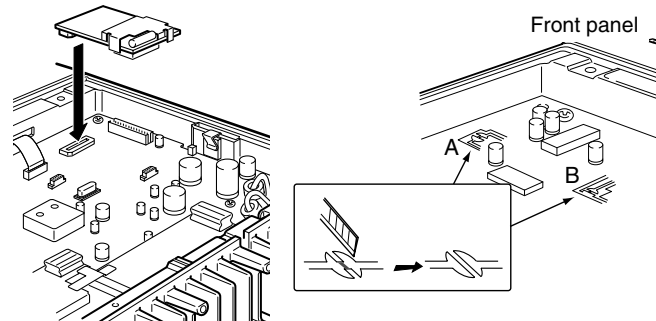

NOTE: Be sure to re-solder the above disconnected points, otherwise no TX modulation or AF output is available when you remove the scrambler units.

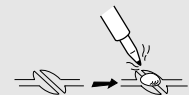

8 CONNECTION AND MAINTENANCE

■ Optional OPC-617 installation

Install the OPC-617 as shown below.

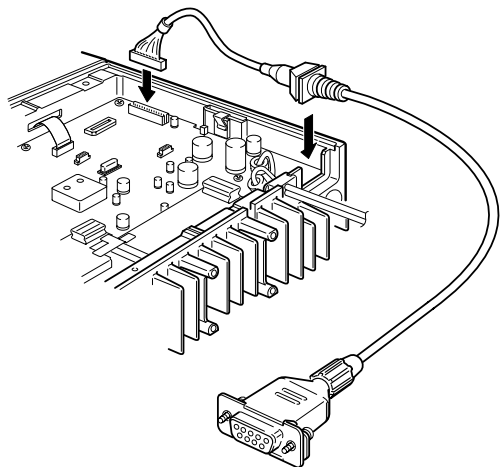

OPTIONAL CABLE PIN ASSIGNMENT

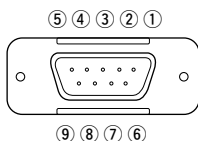

- | | |
|-------------------------------------|-------------------------------------|
| ① LCD backlight cont. IN | ⑥ Horn drive cont. OUT |
| ② AF OUT for PA, RX
SP. function | ⑦ AF GND for PA, RX
SP. function |
| ③ Det. AF OUT | ⑧ Det. AF GND |
| ④ Mod. IN | ⑨ Mod. GND |
| ⑤ NC | |

■ Antenna

A key element in the performance of any communication system is an antenna. Ask your Dealer about antennas and the best places to mount them.

■ Fuse replacement

Two fuses are installed in the supplied DC power cable. If a fuse blows or the transceiver stops functioning, track down the source of the problem, if possible, and replace the damaged fuse with a new rated one.

□ Fuse rating : 15 A

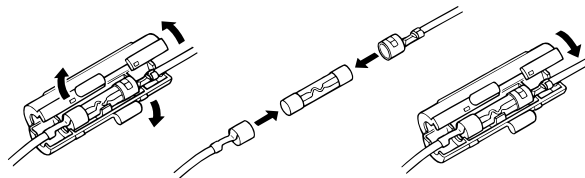

■ Cleaning

If the transceiver becomes dusty or dirty, wipe it clean with a dry, soft cloth.



AVOID the use of solvents such as benzene or alcohol, as they may damage transceiver surfaces.

■ Cloning

Cloning allows you to quickly and easily transfer the programmed contents from one transceiver to another transceiver; or data from PC to a transceiver using the optional CS-F600(MPT) CLONING SOFTWARE.

PC-to-transceiver cloning

Please refer to the HELP file that comes with the CS-F600 (MPT) CLONING SOFTWARE.

CAUTION: Imprudent cloning operation causes a cloning error. In such a case, memory contents may be lost. Cloning must then be repeated.

10 OPTIONS

SP-22 EXTERNAL SPEAKER

Compact and easy-to-install.

Input impedance : 4 Ω

Max. input power : 5 W

HM-100N/HM-100TN/HM-152/HM-152T/HM-148

- HM-100TN/HM-152T : DTMF microphone
- HM-148 : Heavy duty microphone

SM-25

Desktop microphone.

UT-109/UT-110 (#02) VOICE SCRAMBLER UNIT

- UT-109 : Non-rolling type (max. 32 codes)
- UT-110 : Rolling type (max. 1020 codes)

OPC-617 ACC CABLE

Allows you to connect to an external terminal.

OPC-822 MAP27 INTERFACE CABLE

Allows you to use MAP27 serial interface.

Count on us!

A-6162H-1EX-①
Printed in Japan
© 2005 Icom Inc.

(MPT)

Icom Inc.
1-1-32 Kamiminami, Hirano-ku, Osaka 547-0003, Japan